

13 series is designed in strict accordance with the requirements of the mobile machinery industry. Its compact shape can be fully integrated with the hydraulic cylinder with limited head space. The high versatile IP68 profile housing offers full protection for use in harsh environments with high contamination and presence of dust. If the hydraulic cylinder is used with a special connector, the protection level is up to IP69K. Vibration and shock rating are also high-level 25g / 10-2000Hz and 100g (single shock).

It adopts the non-contact magnet-rostrictive measuring technology for precise, accurate, and absolute measurement. The non-contact feature provides exceptional ease of installation and guarantees almost unlimited mechanical life expectancy.



Specifications

Order Code	13
Output	Voltage / Current
Measurement Type	Linear displacement
Resolution	<500mm ±0.10mm, 700mm ±0.18mm, 1000mm ±0.24mm 1250mm ±0.30mm, 1750mm ±0.42mm,
Repeatability	< ±0.005% of full scale
Non-Linearity	< ±0.04% of full scale (minimum ±100µm for 60mm damping zone) < ±0.08% of full scale (for 36.5mm damping zone)
Input Voltage	+12V / +24Vdc
Input Protection	Polarity protection up to -30Vdc, Over voltage protection up to 36Vdc
Power Consumption	1W
Dielectric Strength	500Vdc (DC ground to machine ground)
Operation Temp.	-40 to 85°C, Humidity 90% non-condensing
Sealing	IP 68 (IP 69K when installed inside a cylinder with M12x1 connection type)
Vibration Rating	25g / 10-2000Hz / IEC standard 68-2-6
Shock Rating	100g single hit per IEC standard 68-2-27
EMC	Emission EN 61000-6-3, Immunity EN 61000-6-2, EN 61000-4-2/3/4/6
Pressure Rating	350 bar / 530 bar peak
Material	Stainless Steel

Order Code

1 3 M X X X X X X X X X X X X X X X X

Output

011 = 0.25 - 4.75V 101 = 4 - 20mA
 012 = 0.5 - 4.5V 104 = 20 - 4mA
 013 = 4.75 - 0.25V
 014 = 4.5 - 0.5V

Connection Type

N__A = 4 single wires (20AWG)
 N__E = 4 single wires , M12x1 IP69K,4pin (pin assignment 2-3-4)
 N__G = 4 single wires , M12x1 IP69K,4pin (pin assignment 1-3-4)
 N__H = 4 single wires , M12x1 IP69K,4pin (pin assignment 1-2-3)
 Ex. : 06 = 60mm wire length
 25 = 250mm wire length
 T__A = integral PUR shielded cable, pigtail for wire termination
 Ex. : 10 = 1.0 meter cable length (0.5 meter mini.)
 35 = 3.5 meter cable length

Sensor Styles

1 = 10mm dia. rod, damping zone 60mm
 2 = 10mm dia. rod, damping zone 36.5mm
 3 = 7mm dia. rod, damping zone 60mm

Magnet Type

1 = Outer dia. 33mm, inner dia. 13.5 ring magnet
 2 = Outer dia. 25.4mm, inner dia. 13.5 ring magnet
 3 = Outer dia. 17.4mm, inner dia. 13.5 ring magnet

Stroke Length (mm)

0075, 0100, 0125, 0150, 0175, 0200, 0225
 0250, 0275, 0300, 0325, 0350, 0375, 0400
 0425, 0450 (25mm increment after)



4 single wires



IP69K M12x1

Pin Assignments

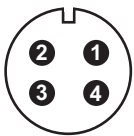

4 pin M12
(View toward sensor pins)

	N__E	N__G	N__H
1	N.C.	+24 Vdc	+24 Vdc
2	+24 Vdc	N.C.	Output
3	0 Vdc	0 Vdc	0 Vdc
4	Output	Output	N.C.

Cable Assignments

Color	T__A	N__A
Brown	+24 Vdc	+24 Vdc
Green	Output	Output
Yellow	N.C.	N.C.
White	0 Vdc	0 Vdc

Specifications

Order Code	13 M
Output	Direct CANopen or CAN J1939
Measurement Type	Linear displacement
Resolution	<500mm ±0.10mm, 700mm ±0.18mm, 1000mm ±0.24mm 1250mm ±0.30mm, 1750mm ±0.42mm,
Repeatability	< ±0.005% of full scale
Non-Linearity	< ±0.04% of full scale (minimum ±100µm for 60mm damping zone) < ±0.08% of full scale (for 36.5mm damping zone)
Input Voltage	+12V / +24Vdc
Input Protection	Polarity protection up to -30Vdc, Over voltage protection up to 36Vdc
Power Consumption	1W
Dielectric Strength	500Vdc (DC ground to machine ground)
Operation Temp.	-40 to 85°C, Humidity 90% non-condensing
Sealing	IP 68 (IP 69K when installed inside a cylinder with M12x1 connection type)
Vibration Rating	25g / 10-2000Hz / IEC standard 68-2-6
Shock Rating	100g single hit per IEC standard 68-2-27
EMC	Emission EN 61000-6-3, Immunity EN 61000-6-2, EN 61000-4-2/3/4/6
Pressure Rating	350 bar / 530 bar peak
Material	Stainless Steel

Pin Assignments

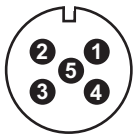

5 pin M12
(View toward sensor pins)

	N__F
1	N.C.
2	+12/24 Vdc
3	0 Vdc
4	CAN High
5	CAN Low

Cable Assignments

Color	N__A
Brown	+12/24 Vdc
Green	CAN Low
Yellow	CAN High
White	0 Vdc

Color	T__A
Red	+12/24 Vdc
Green	CAN Low
Yellow	CAN High
White	0 Vdc



IP69K M12x1



4 single wires

mobile hydraulic technology ...





Output

C01 = CANopen
 J01 = SAE J1939

Baud Rate

0 = 1000 kBit/s 4 = 125 kBit/s
 1 = 800 kBit/s 6 = 50 kBit/s
 2 = 500 kBit/s 7 = 20 kBit/s
 3 = 250 kBit/s 8 = 10 kBit/s

Node-ID

CANopen : hex 01 to 7F (default 7F)
 SAE J1939 : hex 01 to FD (default FD)

Connection Type

N__A = pigtail (stripped conductors) no termination (20AWG)
 N__F = 4 single wires , M12x1 IP69K,5pin (pin assignment 2-3-4-5)
 Ex. : 06 = 60mm wire length
 25 = 250mm wire length
 T__A = 4 wires integral PUR shielded cable, pigtailed
 Ex. : 10 = 1.0 meter cable length (0.5 meter mini.)
 35 = 3.5 meter cable length

Sensor Styles

1 = 10mm dia. rod, damping zone 60mm
 2 = 10mm dia. rod, damping zone 36.5mm
 3 = 7mm dia. rod, damping zone 60mm

Magnet Type

1 = Outer dia. 33mm, inner dia. 13.5 ring magnet
 2 = Outer dia. 25.4mm, inner dia. 13.5 ring magnet
 3 = Outer dia. 17.4mm, inner dia. 13.5 ring magnet

Stroke Length (mm)

0075, 0100, 0125, 0150, 0175, 0200, 0225
 0250, 0275, 0300, 0325, 0350, 0375, 0400
 0425, 0450 (25mm increment after)



Installation Dimensions

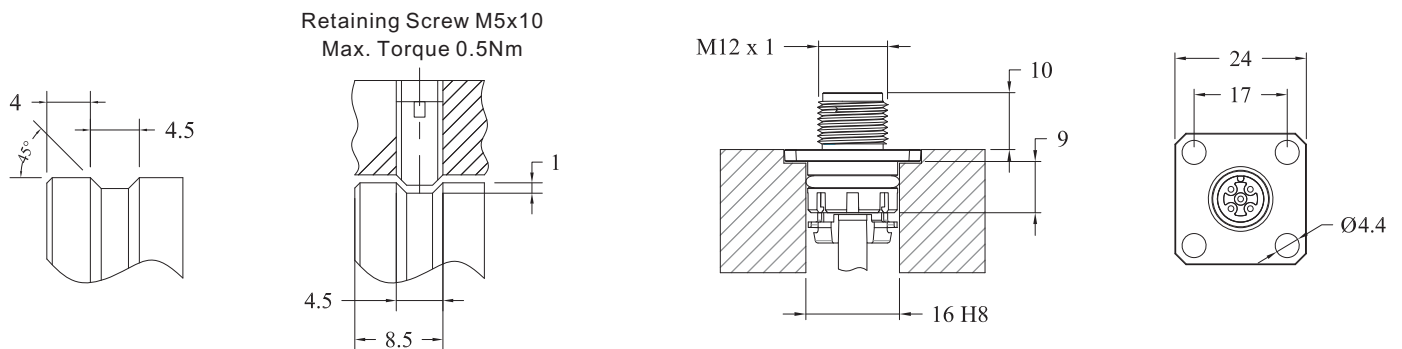
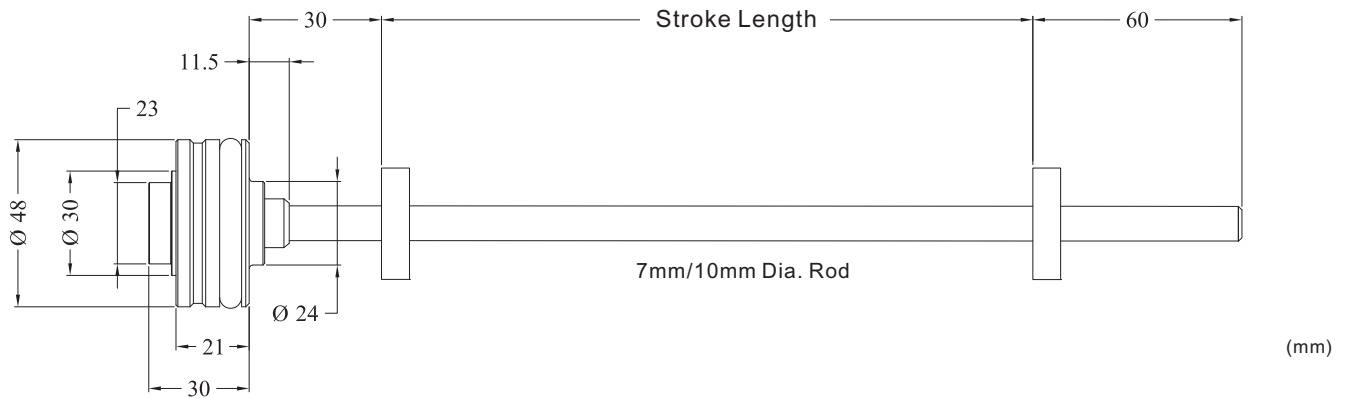

Installation

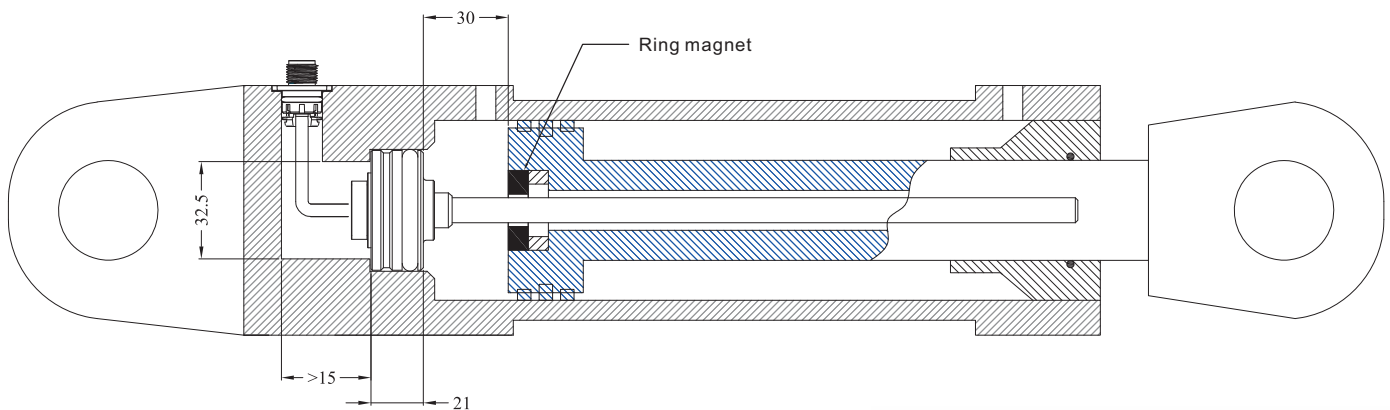

Remark

- 1) Use a non-ferrous circlip to fasten the magnet.
- 2) Minimum drilling for a 10mm rod should be 13.5mm.
- 3) No less than 3mm clearance between the end of the sensor rod and the bottom of the rod bore at full retraction.



Discription
Order Code

Outer Dia. 17.4 mm ring
1700 951 025

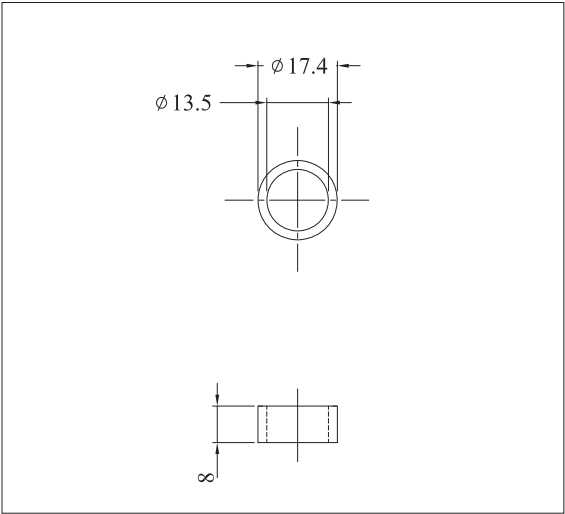

Material
Weight

Plastic
~4g

Outer Dia. 25.4mm ring
1700 951 023

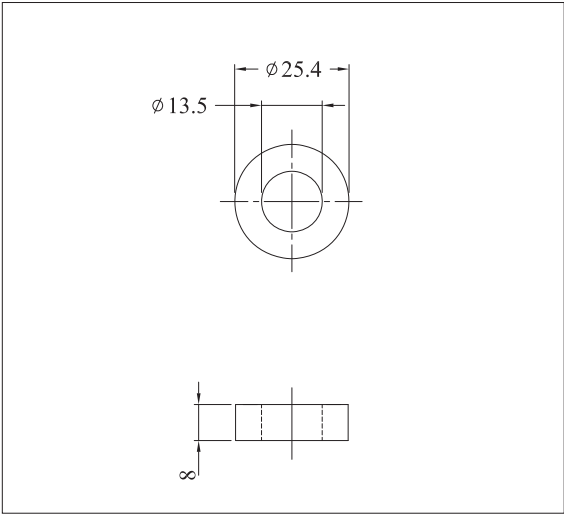

Plastic
~8g

Discription
Order Code

Outer Dia. 33mm ring
1700 951 001

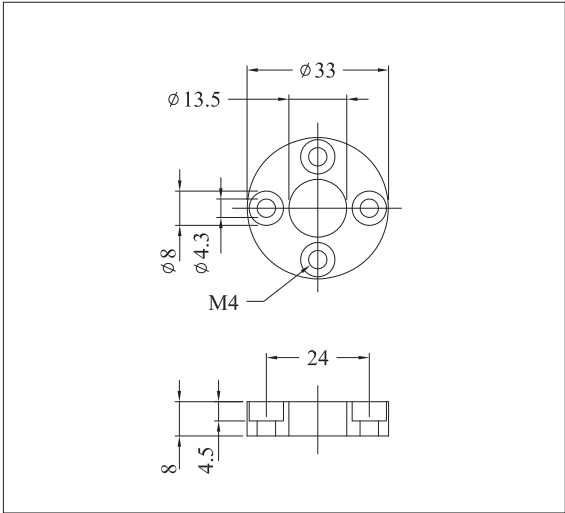

Material
Weight

Plastic
~8g

Discription
Order Code
Material

Dia. 33mm Spacer
1700 951 002
Plastic

